

ANTIETAM VALLEY MUNICIPAL AUTHORITY
502 BUTTER LANE, READING, PENNSYLVANIA 19606
PHONE (610) 779-0150
FAX (610) 779-1939

APPLICATION FOR SEWER SERVICE

Date of Application _____

Date of Service _____

The undersigned hereby makes application to the Antietam Valley Municipal Authority for sewer service.

The undersigned hereby agrees to pay immediately upon presentation, all bills for sewer service furnished to the hereinafter described premises, and agrees to comply with all provisions of the current RULES & REGULATIONS and the Sewer Rents, Rates and Charges, together with payment of the actual construction cost (if any) incurred by the Authority in installing the sewer lateral (s), and agrees to be bound by all of the terms thereof.

The undersigned represents as follows:

1. Location and full address of premises to be served:

2. Address to which bills are to be delivered:

3. Applicant is (circle) Owner - Agent - Tenant - of the premises.

4. Name of Plumber who will perform all work:

The following number of family dwelling units and/or commercial establishments will be connected to the house sewer lateral serving the above-described property:

(a) Dwelling units _____ (number)

(b) Commercial establishments _____ (number & type)

The property is supplied with water by :

() Mount Penn Borough Municipal Authority

() other source of supply as follows: _____

In consideration of the granting of this application, the undersigned agrees:

1. To accept and abide by all provisions of Antietam Valley Municipal Authority Resolutions or any amendments thereto, concerning the sanitary sewer collection system owned by Antietam Valley Municipal Authority, Plumbing Code Ordinances, or any amendments thereto, and all applicable Ordinances, Resolutions, Rules and Regulations now in effect or which may be adopted by the Borough of Mount Penn or Lower Alsace Township in the future.

2. To maintain the house sewer at no expense to the Authority.

3. To notify the respective municipal plumbing inspector when the house sewer is ready for inspection and connection to the public sewer such notification to be at least twenty-four (24) hours before any portion of the work is covered or the connection made.

Please sign and file with your tap-in fee of \$4,000 per billing unit and a connection fee deposit (in escrow)* of \$1,000 per connection with the Antietam Valley Municipal Authority.

**Antietam Valley Municipal Authority
502 Butter Lane
Reading, PA 19606**

Signed _____
Applicant

Address _____

Telephone No: _____

Date: _____

*** THE ESCROW ACCOUNT IS A NON-INTEREST BEARING ACCOUNT**

STANDARD DETAIL

SPOTTS, STEVENS AND McCOY INC.
CONSULTING ENGINEERS
WYOMISSING, PENNSYLVANIA 19610

TYPICAL HOUSE CONNECTION WITH TRAP

R.R.P. 6-22-72	RJD CTS	S - S - 13	2
MADE	APP'D.	DRAWING NUMBER	REV.
			11/8/78

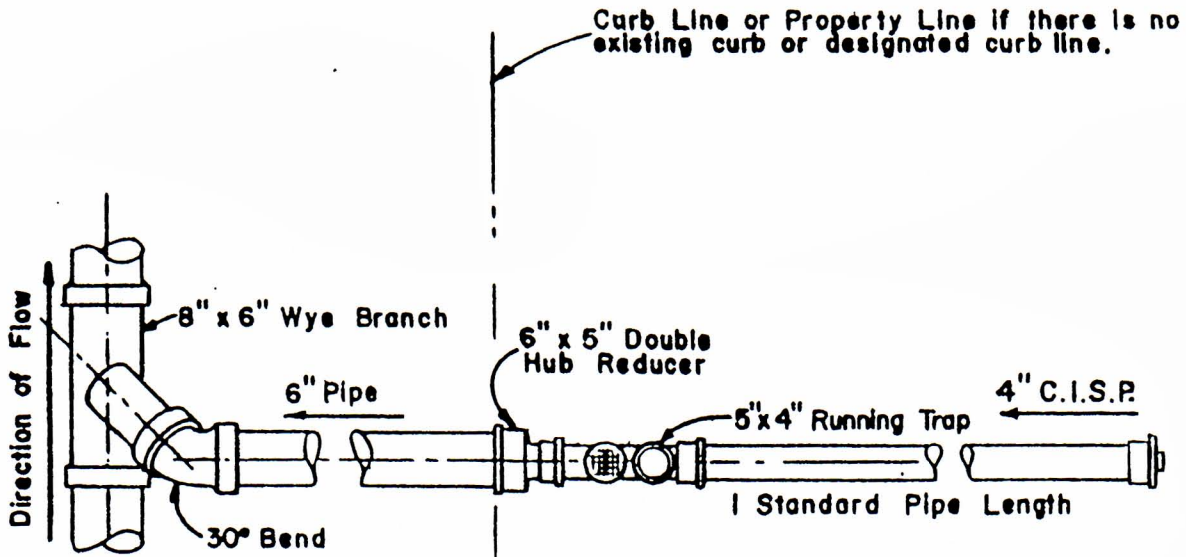

PLAN

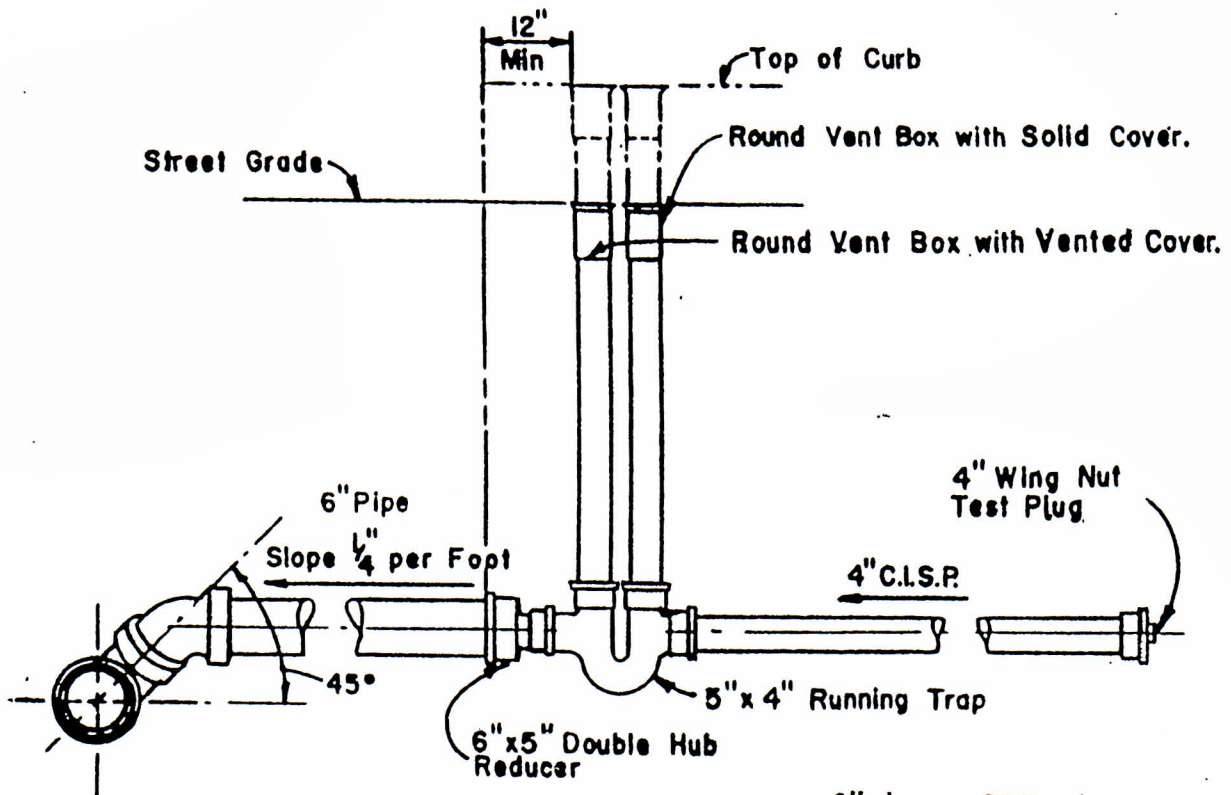

ELEVATION

NOTE: All Joints to be Calked in
Accordance with Local Plumbing
Code.

6" base 2RC stone
pipe must be completely
covered by stone
all joints must be rubber
gasket type connections
all backfill must be st